

# J113B 型 (25 吨) 250 千牛卧式冷室压铸机

Model J113B (25Ton)

250kN Horizontal Plunger Cold Chamber Die Casting Machine

## 用途和特点

本机器可适用于汽车、仪器仪表、电器、日用五金等工业部门，大批量生产铝、锌、铜等有色金属压铸件。

机器采用电气控制液压驱动的传动系统，合型刚性好，使用安全，压射机构采用二级压射系统，快慢两种速度均可单独调节。

本机器具有手动和半自动两种工作制。

## Features and applications

The machine is widely used for mass production of foundry goods made of non-ferrous metal such as aluminum, zinc and copper in the industries of automobiles, motorcycles, meters and instruments, hardware.

Electronics control, hydraulic drive, locking that is tensile, operational safety, 2-step injection system that is fast and slow speed can be separately adjusted.

There're two kinds of driving modes as manual and semiauto.

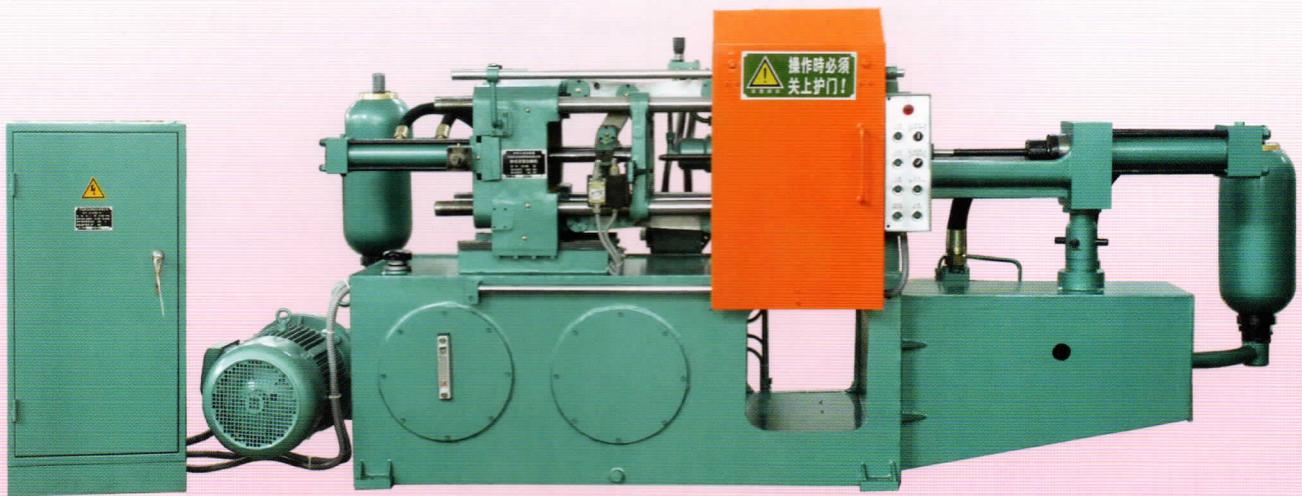

**宁波银山机械有限公司**  
Ningbo Yinshan Machinery Co., Ltd.  
**宁波东方压铸机床有限公司**  
Ningbo Dongfang Die-casting Machine Tool Co., Ltd.

地址：中国浙江省宁波市邱隘镇

Add: Qiulai Town, Ningbo City Zhejiang Province, China

电话 (Tel): (0574) 88411774 88411600

传真 (Fax): (0574) 88413571

邮编 (P. C.): 315101

E-mail: sales@china-dfyz.com

Http: //www.china-dfyz.com

## 主要规格和参数 Main Specifications And Parameters

合型力 Die locking force	kN	250
动型板尺寸(水平×垂直) Size of moving platen(H×V)	mm	400×400
拉杠内间距(水平×垂直) Inner space between the bars(H×V)	mm	240×240
压型厚度(最小/最大) Thickness of die block (Min./Max)	mm	120/320
动型板行程 Stroke of moving platen	mm	200
顶出行程 Ejection stroke	mm	50
顶出力 Ejection force	kN	26.9
压射力 Injection force	kN	35
标准压室直径 Diameter of shot sleeve	mm	25, 30

一次金属注入量(铝) Dosage of fluid metal per shot(AL)	kg	0.3
铸件最大投影面积 Max. Projecting area of casting	cm <sup>2</sup>	50.5
压射比压(小~大) Injection Pressure (Min. ~ Max. )	MPa	49.5 ~ 71.3
压射行程 Injection stroke	mm	250
空循环时间 Dry cycle	s	4
液压系统工作压力 Pipe line pressure	MPa	7
电动机功率 Motor power	kW	7.5
机器重量 Machine weight	kg	2000
机器外形尺寸(长×宽×高) Overall dimensions(L×W×H)	mm	3030×1060×1300

主要规格和参数如有更改,恕不另行通知  
If these specifications and parameters are changed, we won't inform you

### 模具安装图 CHART FOR DIE MOUNTING

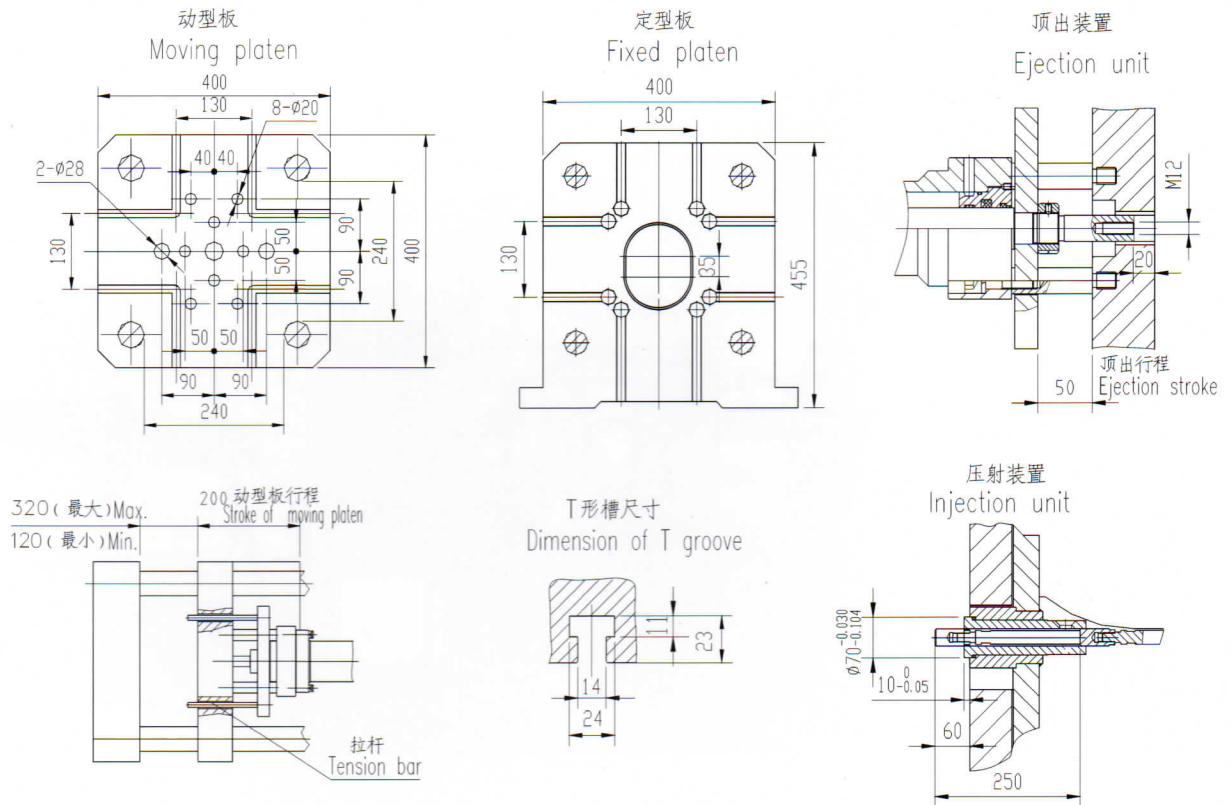

### 基础安装图 CHART FOR INSTALLATION FOUNDATION

